



Installation/Operation Instructions

Fiber Optic Video, Audio & Data Transmission System

Part Number:

DT/DR-AiphoneAX2-x

(2-Channel Video Tx/Rx & 2-Channel Audio,

4-Channel Contact Closure Transceiver)

Meridian Technologies, Inc.
700 Elmont Road, Elmont NY 11003
Telephone : 516. 285. 1000 Fax: 516. 285. 6300
E-mail : sales@meridian-tech.com
Web: www.meridian-tech.com
Document Version 1.0
02/16/2010

Table of Contents

1.0	Product Description	3
2.0	Installation.....	3
3.0	Product Signal Format & Specifications	3
4.0	Operating	5
4.1	Status indicators.....	5
4.2	Connector Pinouts	7
4.3	Audio SIM Jumper Settings	8
5.0	Front Panel Pinout Assignment Diagram	8
6.0	Product Part Number Variations	11
7.0	Troubleshooting.....	11

1.0 Product Description

Meridian's product series DT-AiphoneAX2-x and DR- AiphoneAX2-x are fiber optic modems that transmit two channels of uni-directional digitized video, 2 channels of bi-directional audio and four channel of bi-directional contact closure signals over one optical fiber using digital transmission technologies. The video is 8-bit resolution and uses Meridian's standard 2-slot wide chassis mount card assembly and plugs into the following Meridian chassis: SR-1000/S, SR-1001/S, SR-1200/S, SR-1500/S, and SR-2001 & SR-2000 series 19" equipment chassis.

The digital modules consist of various plug-in personality function cards or SIMs. The top card is the optical card that contains the fiber optic interface. The bi-directional optical input/output connector is located on the right side of both the transmitter (DT) and receiver (DR) modules. The second SIM contains the video coaxial interface. The audio input/output connections are located on Port 3. The bottom SIM card Port 4 contains the bi-directional Contact Closure signals.

2.0 Installation

Series DT-AiphoneAX2-x and DR-AiphoneAX2-x products are two-slot wide cards and, as such, occupy two slots in Meridian's standard chassis (SR-1000/S, SR-1001/S, SR-1200/S, SR-1500/S, and SR-2001 & SR-2000 series 19" equipment chassis). To install in the chassis, orient the card with the Meridian logo at the top of the module and slide onto the top and bottom card guides in the chassis. Press securely on the top and bottom of the module to ensure that it is fully seated in the chassis so that the electrical connector mates with the chassis-mounted motherboard. Once installed, manually tighten the two thumbscrews located at the top and bottom of the card. Do not use tools to secure these and do not over tighten.

Note: A fully loaded subrack should have forced-air cooling to avoid excessive heat generation inside the chassis. A fan assembly tray (P/N FA-2000) with three (3) fans is available and should be installed under the 19" SR-2000/1 whenever possible.

3.0 Product Signal Format & Specifications

The DT & DR- AiphoneAX2-x series products transmit and receive the following signals:

Signal Type	Channels	Transmit	Receive
NTSC/PAL video	2	DT-AiphoneAX2	DR-AiphoneAX2
Audio (6000, unbalanced)	2	Yes	Yes
Dry contact closure	4	Yes	Yes

The tables below identify the specifications for the various signals that these modems transmit/receive.

Video	
Format	NTSC, PAL, SECAM
Voltage/Impedance	1Vp-p, 75 ohm, 1 .5Vp-p (max)
Differential Gain	<0.6%
Differential Phase	<0.3°
SNR	>60dB (weighted)
Return Loss	>30dB
Field Tilt	<0.5%
Audio	
In/Out Impedance	600 Ohm, unbalanced/unbalanced
Frequency Response	10Hz to 20KHz
SNR	>90dB (weighted) @ 1KHz
In/Out Level	-8 to +8dBm (4Vp-p, max)
THD	<0.01% @ 1KHz
Digitized Resolution	24 bit
Contact Mapping	
Input	Contact closure to ground
Output	Isolated contact closure outputs
Output Contact Rating	0.3A @ 30VAC/DC
Contact bounce time	5msec
Connectors	High Density DB15 Female
Connectors	
Video	75 Ohm BNC w/gold center pin
Audio	DB9 Female
Dry contact closure	DB15 Female
Optical	Singlemode – ST or FC Multimode – ST

Optical Specifications						
Fiber Type/Size (um)	Optical Output (dBm)	Rx Sensitivity (dBm)	Optical Budget (dB)	Wavelength (nm)	Optical connector	Optical Dynamic Range (dB)
Multimode (FP Laser) 62.5/125	-3	-24	21	1300/850	ST	24
Singlemode (FP Laser) 9/125	-3	-24	21	131 0/1 550	ST, FC	24
Singlemode (DFB Laser) 9/125	+3	-24	27	131 0/1 550	ST, FC	24

4.0 Operating

Video – Each of the two BNC video connectors accepts a standard NTSC/PAL video input signal (DT module) and transmits these signals to the receive unit (DR module). The respective video output signal is located on the same channel (location) as the input video signal. Connect the input video signal to the appropriate BNC video input connector on the transmitter module (DT-AiphoneAX2) and the output video connector on the associated port on the receiver module (DR-AiphoneAX2).

Audio - Connect the audio source to one of the channel’s input pins as shown in section 4.2. Connect an audio output device to the associated channel’s output pins on the other module. To obtain optimal performance, the audio input level should be set to 0dB. The audio output level will track the input level. Once proper operation is verified, the other channels can be connected per the pinout diagram in this manual.

4.1 Video, Audio and Contact Mapping Status indicators

The figures at the end of this document show the connector and LED indicator locations for the various video, audio & Contact Mapping status indicators on the transmitter and receiver modules. There are a number of diagnostic indicators on the front panel of each module. In addition, each of the video input/output channels has indicators associated with them to provide quick visual indications of the channel activity. These indicators for each of the video, audio & Contact Mapping channels are listed below:

Transmitter (DT- AiphoneAX2) Indicators		
Indicator	Location	Function
Tx carrier	Under optical output connector	Optical output (Green – OK, Red – error)
Power	Left side of module	Green – ON
Video #1	Under video input connectors	Green – Sync received
Video #2	Under video input connectors	Video signal – Green OK, Red – video overload

Receiver (DR- AiphoneAX2) Indicators		
Indicator	Location	Function
Rx Optical signal	Under optical output connector	Optical input (Green – OK, Red – error)
Rx Carrier	Under optical output connector	Optical Carrier input (Green – OK, Red – error)
Power	Left side of module	Green – ON
Video #1 (each input)	Under video input connectors	Green – Sync received
Video #2 (each input)	Under video input connectors	Video signal – Green OK, Red – video overload

Each audio input/output channel has four LED status indicators located under the associated audio I/O connector. Two adjacent LEDs are associated with each audio input channel and two are associated with the respective audio output channel. The table below shows the relationship between the connectors (I/O channels) and LEDs.

Audio Input/Output Status Indicators (Port 3)	
LED	DT/DR-AiphoneAX2-x
1	Input 1 – Present
2	Input 1 – Overload
3	Input 2 – Present
4	Input 2 – Overload
5	Output 1 – Present
6	Output 1 – Overload
7	Output 2 – Present
8	Output 2 – Overload

Audio input PRESENT LEDs – Each of the LEDs associated with a specific audio input channel will light when the audio input source is connected and has a signal level greater than -8dB

Audio input OVERLOAD LEDs – when the audio input level of any channel exceeds +8dB, the associated audio channel input Overload LED will turn on indicating that the audio input level is too high and distortion on the output may result.

Audio output PRESENT LEDs – This light will turn on when the audio input on the transmit side is present, the DXA & DXB units are powered and the fiber is connected between the two modems.

Audio output OVERLOAD LEDs – These lights will light when the respective audio input on the transmit side is over +8dB. Since the audio output level will track the audio input level, this light should not illuminate when the audio input is below the overload condition (+8dB)

 The table below identifies the input/output functions LED status indicators for contact SIM card.

Contact Mapping Input/Output Status indicators (Port 4)	
LED	DT/DR-AiphoneAX2-x
1	Channel 1 - input present
2	Channel 1 - output present
3	Channel 2 - input present
4	Channel 2 - output present
5	Channel 3 - input present
6	Channel 3 - output present
7	Channel 4 - input present
8	Channel 4 - output present

4.2 Audio & Contact Mapping Signal Connector Pinouts

The DT & DR-AiphoneAX2-x Audio channel connector pinouts are shown in the table below:

Audio connector	
Pinout	DT/DR-AiphoneAX2-x
1	Audio Ch 1 Output (-)
2	Audio Ch 1 Output (+)
3	Audio Ch 2 Output (-)
4	Audio Ch 2 Output (+)
5	GND
6	Audio Ch 1 Input (-)
7	Audio Ch 1 Input (+)
8	Audio Ch 2 Input (-)
9	Audio Ch 2 Input (+)

The audio board (SIM) is inserted in the module at the bottom (port 3).

Contact Mapping Connector	
Pinout	DT/DR-AiphoneAX2-x
1	Ch 1 Input
2	Ch 2 Input
3	Ch 3 Input
4	Ch 4 Input
5	GND
6	Ch 1 Output
7	Ch 1 Output
8	Ch 2 Output
9	Ch 2 Output
10	Ch 3 Output
11	Ch 3 Output
12	Ch 4 Output
13	Ch 4 Output
14	NA
15	NA

The Contact Mapping board (SIM) is inserted in the module at the bottom (port 4).

The attached figures in section 5.0 show the module front panel and associated connector location & pinouts.

4.3 Audio SIM Jumper Settings

The Audio SIM has 2 jumpers on it (located directly behind the DB9 connector), one for each channel. These jumpers are used to set the input/output impedance of the audio channels. Each audio input channel can be set to either 600ohm (balanced) or 47kohm (unbalanced) input impedance (Hi-Z). Each audio output channel's impedance can be set to either 600 ohm, balanced or low impedance (Low-Z). The default setting is 600 ohm, balanced.

The figures below illustrate these jumpers and how they are configured

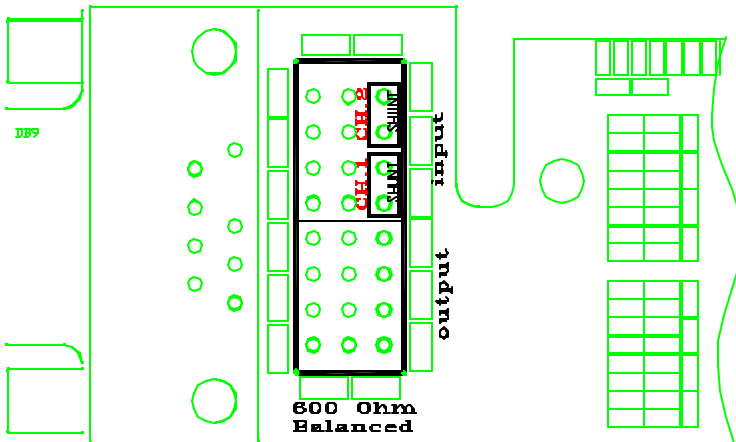

Audio jumper settings for 600Ohm
Balanced Input/Output

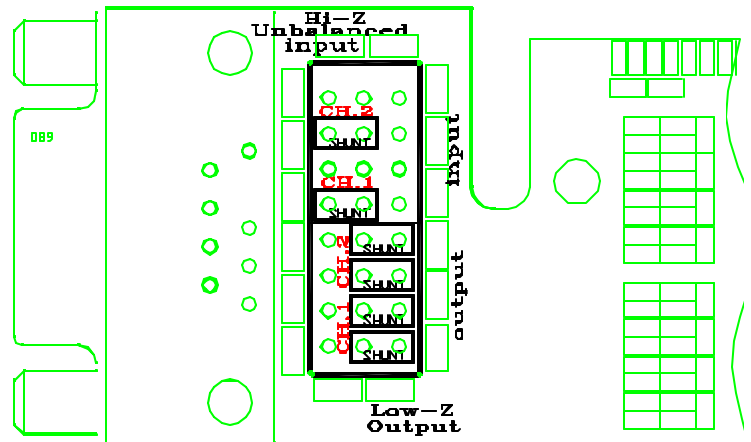

Audio jumper settings for Hi-Z
Unbalanced or Low-Z Input/Output

5.0 Front Panel Pinout Assignment Diagram

Figures 5.1 and 5.2 below show the front panel layout, connector location and pinout assignment for both the DT & DR modules.

DT- AiphoneAX2-X

PINOUT DIAGRAM

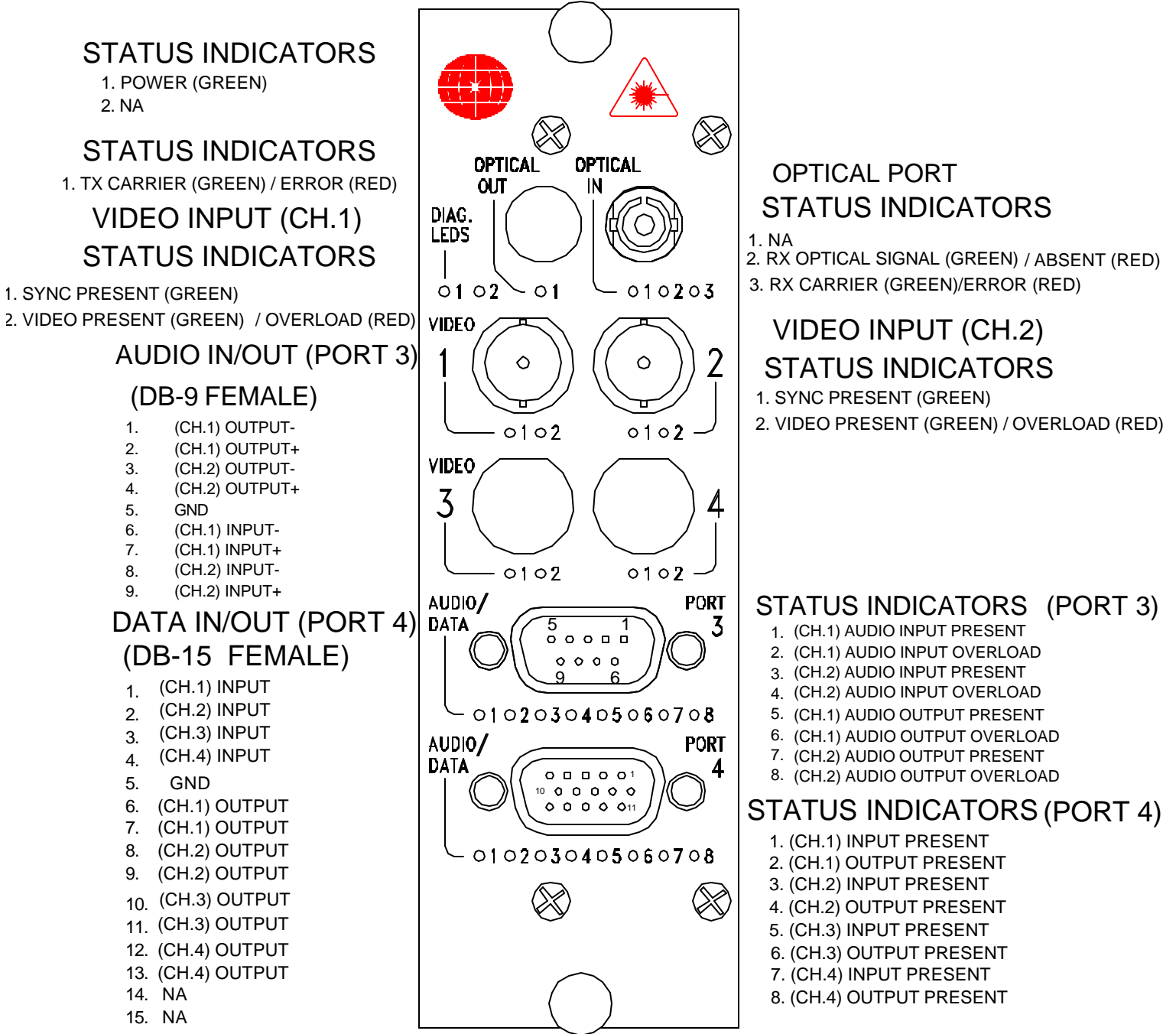

Figure 5.1

DT- AiphoneAX2-X Front Panel Layout Diagrams

DR- AiphoneAX2-X

PINOUT DIAGRAM

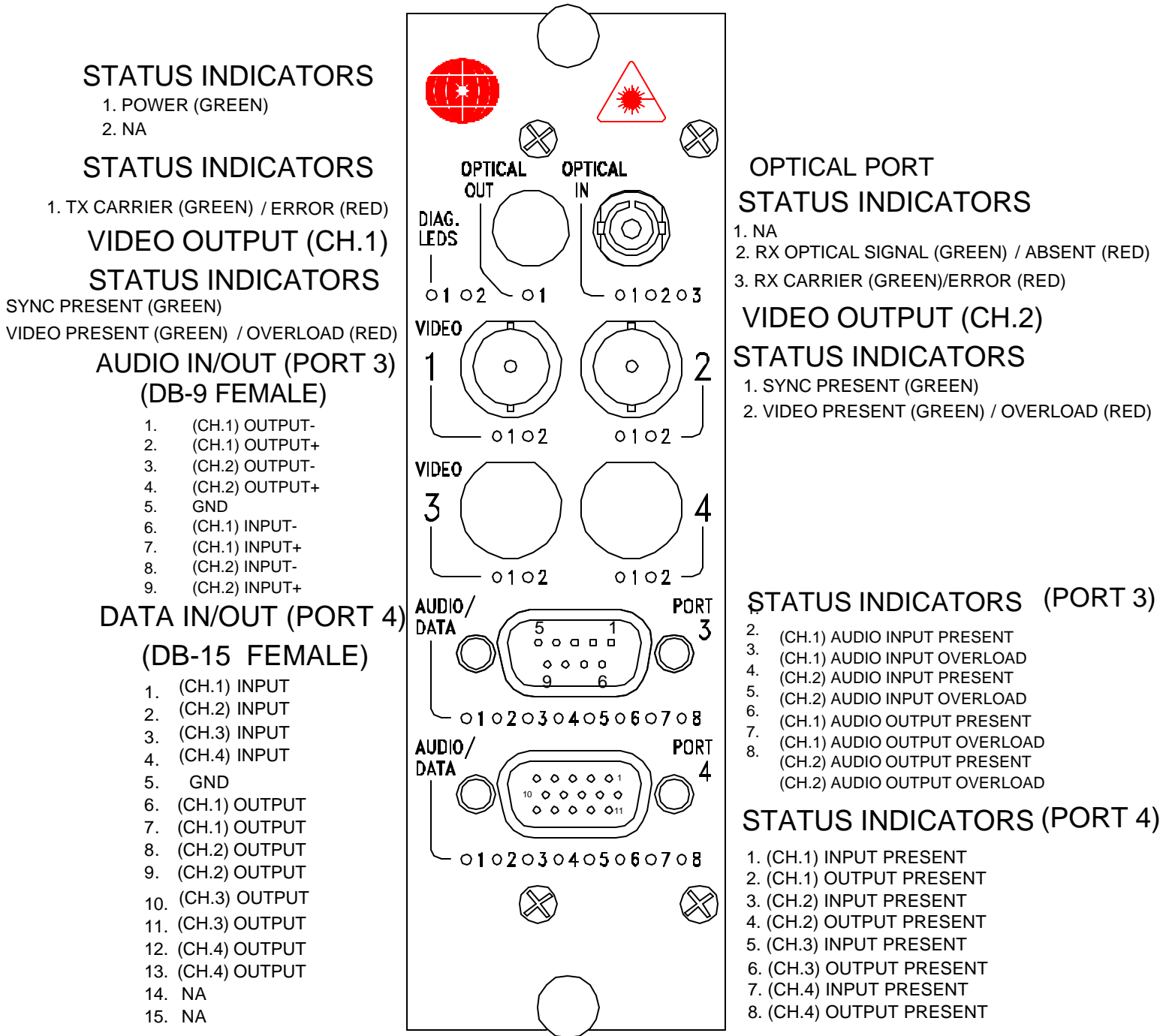

Figure 5.2

DR- AiphoneAX2-X Front Panel Layout Diagrams

6.0 Product Part Number Variations

The table below lists the various part numbers associated with different module types:

Basic module description:

Video: 2-channels, one way
Audio: 2-channels, bi-directional
Dry contact closure: 4-channels, bi-directional

Transmitter	Receiver	Video Resolution	# Fibers & Type	Wavelength
DT-AiphoneAX2-2	DR- AiphoneAX2-2	8-bit	1 (MM)	1310/850nm
DT-AiphoneAX2-5	DR- AiphoneAX2-5	8-bit	1 (SM)	1310/1550nm

For proper operation, it is necessary to match the transmitter (DT) with the associated receiver module (DR).

7.0 Troubleshooting

Below is a listing of several problems that may arise during the installation & operation of the modules. If you are having difficulty installing or operating the modules please refer to this list below.

Problem: *Module does not fit in chassis slots*

Action: Check module orientation. Meridian “Globe” must be oriented on the top left hand side of the module. Make sure the card guides in the chassis are aligned with the extrusion on the module

Problem: *Card power LED does not light when power to the module/subrack is applied or power indicator turns on and off*

Action: Check power supply to ensure that it is plugged in and turned on. If flashing continues, move module to another chassis or location in the same chassis, if available.

Problem: *No video at output of module*

Action: Check to ensure that the video channel-specific LEDs are on (Green). Also, check to ensure that the optical LEDs are ON. If no video is still present, check to ensure that the monitor is ON and the video cable is connected to the correct video port on the Rx module.

Problem: *Video image is dark*

Action: Check the iris control on the camera to ensure that it is open to the proper amount for the conditions.

Problem: *Video image is too bright and appears overexposed*

Action: Check the Video overload indicator on the Rx module. If it is Red, the video signal level is too high and the CCTV iris should be checked to ensure that it is open properly for the conditions.

Problem: *No Audio*

Action: Check the audio input status indicator lights on the transmit module to ensure that they are on (indicating an audio input signal). Also check the audio output status indicator lights on the corresponding receiver module to ensure that the signal is being transmitted and received. If not, please check the audio input/output and fiber connections.

Problem: *Low/High Audio output*

Action: Check to ensure that the input/output impedance properly matches the impedance of the audio input source and output device.

Problem: *Audio distortion on output*

Action: Check the status of the associated channel input/output Overload LEDs. If they are on, reduce the audio input level at the source to bring it below the overload condition. This should resolve problem.

Problem: *No Contact Closure transmission*

Action: Check the individual contact closure channel input status indicator lights #1 through 4 to ensure that the lights toggle on and off as the contact is closed and opened. These lights are located below the corresponding DB15. Also check the corresponding contact closure output lights (#1 through 4) on the receiver module to see if the corresponding lights are activated when the corresponding input contact is closed. If not, please check the data input/output and fiber connections.

If the problem still persists after reviewing the above items, please contact Meridian technical support (516-285-1000).