



Installation/Operation Instructions

Fiber Optic Video & Audio **Transmission System**

DT/DR-4V(W)4A Series

(4-Channel Video, 4 Channel Audio
Transmitter/Receiver)



Meridian Technologies, Inc.
700 Elmont Road, Elmont NY 11003
Telephone : 516. 285. 1000 Fax: 516. 285. 6300

E-mail : sales@meridian-tech.com

Web: www.meridian-tech.com

Document Version 1.0

08/21/2009

Table of Contents

1.0	Product Description.....	3
2.0	Installation	3
3.0	Operation	3
3.1	Video & Audio Status indicators	4
4.0	Audio Signal Connector Pinouts	6
5.0	Specifications.....	6
6.0	Audio SIM Jumper Settings.....	7
7.0	Front Panel Pinout Assignment Diagram	8
8.0	Troubleshooting.....	11
	Appendix 1 – Applicable Product Part Number Variations	12

1.0 Product Description

Meridian's product series DT/DR-4V(W)4A-x are fiber optic modems that transmit or receive four 8-bit (or 10-bit) Video channels and four uni-directional audio channels over optical fiber using digital transmission technologies (the exact type and number of channels is determined by the part number guide in Appendix 1). This product series uses Meridian's standard 2-slot wide chassis mount card assembly and plugs into the following Meridian chassis: SR-1000, SR-1000/S, SR-1200/S, SR-1500/S, and SR-2001 & SR-2000 series 19" equipment chassis.

The digital modules consist of various plug-in personality function cards or SIMs. The top card is the optical card that contains the fiber optic interface. The optical output (Tx) connector is located on the left side of the module while the optical input (Rx) connector is located on the right side of the module. The next two SIM cards each contain two video channels. The last SIM card contains four uni-directional audio channels.

2.0 Installation

Series DT/DR-4V(W)4A-x products are two-slot wide cards and, as such, occupy two slots in Meridian's standard chassis (SR-1000, SR-1000/S, SR-1200/S, SR-1500/S, and SR-2001 & SR-2000 series 19" equipment chassis). To install in the chassis, orient the card with the Meridian logo at the top of the module and slide onto the top and bottom card guides in the chassis. Press securely on the top and bottom of the module to ensure that it is fully seated in the chassis so that the electrical connector mates with the chassis-mounted motherboard. Once installed, manually tighten the two thumbscrews located at the top and bottom of the card. Do not use tools to secure these and do not over tighten.

Note: A fully populated subrack should have forced-air cooling to avoid excessive heat generation inside the chassis. A fan assembly tray (P/N FA-2000) with three (3) fans is available and should be installed under the 19" SR-2000/1 whenever possible.

3.0 Operation

Video – Each of the four BNC video connectors accepts a standard NTSC/PAL video input signal (DT module) and transmits these signals to the receive unit (DR module). The respective video output signal is located on the same channel (location) as the input video signal. Connect the input video signal to the appropriate BNC video input connector on the transmitter module (DT-4V4A) and the output video connector on the associated port on the receiver module (DR-4V4A).

Audio - Connect the audio source to one of the channels' input pins as shown in section 4.0. Connect an audio output device to the associated channel's output pins on the other module. To obtain optimal performance, the audio input level should be set to 0dB. The audio output level will track the input level. Once proper operation is verified, the other channels can be connected per the pinout diagram in this manual.

3.1 Video & Audio Status indicators

The figures at the end of this document show the connector and LED indicator locations for the various video and audio status indicators on the transmitter and receiver modules. There are a number of diagnostic indicators on the front panel of each module. In addition, each of the video input/output channels has indicators associated with them to provide quick visual indications of the channel activity. These indicators for each of the video & audio channels are listed below:

Transmitter (DT-4V4A) Indicators		
Indicator	Location	Function
Tx carrier	Under optical output connector	Optical output (Green – OK, Red – error)
Power	Left side of module	Green – ON
Video #1 (each input)	Under video input connectors	Green – Sync received
Video #2 (each input)	Under video input connectors	Video signal – Green OK, Red – video overload

Receiver (DR-4V4A) Indicators		
Indicator	Location	Function
Rx Optical signal	Under optical output connector	Optical input (Green – OK, Red – error)
Rx Carrier	Under optical output connector	Optical Carrier input (Green – OK, Red – error)
Power	Left side of module	Green – ON
Video #1 (each output)	Under video output connectors	Green – Sync received
Video #2 (each output)	Under video output connectors	Video signal – Green OK, Red – video overload

Each audio input/output channel has four LED status indicators located under the associated audio I/O connector. Two adjacent LEDs are associated with each audio input channel and two are associated with the respective audio output channel. The table below shows the relationship between the connectors (I/O channels) and LEDs.

Audio Input/Output Status Indicators			
LED	DT-4V4A (Port 4)	LED	DR-4V4A (Port 4)
1	In 1 Present	1	Out 1 Present
2	In 1 Overload	2	Out 1 Overload
3	In 2 Present	3	Out 2 Present
4	In 2 Overload	4	Out 2 Overload
5	In 3 Present	5	Out 3 Present
6	In 3 Overload	6	Out 3 Overload
7	In 4 Present	7	Out 4 Present
8	In 4 Overload	8	Out 4 Overload

Audio input PRESENT LEDs (DT-4V4A units) – Each of the LEDs associated with a specific audio input channel will light when the audio input source is connected and has a signal level greater than -8dB

Audio input OVERLOAD LEDs (DT-4V4A units) – when the audio input level of any channel exceeds +8dB, the associated audio channel input Overload LED will turn on indicating that the audio input level is too high and distortion on the output may result.

Audio output PRESENT LEDs (DR-4V4A units)– This light will turn on when the audio input on the transmit side is present, the DT & DR units are powered and the fiber is connected between the two modems.

Audio output OVERLOAD LEDs (DR-4V4A units) – These lights will light when the respective audio input on the transmit side is over +8dB. Since the audio output level will track the audio input level, this light should not illuminate when the audio input is below the overload condition (+8dB)

Each data input/output channel has two LED status indicators located under the associated data I/O connector. One LED is associated with each data input and output channel to show activity on both the input (transmit) and output (receive) pins. The table below shows the relationship between the connectors (I/O channels) and LEDs.

4.0 Audio Signal Connector Pinouts

The DT/DR-4V4A Audio channel connector pinouts are shown in the table below:

Transmitter (DT) Module		Receiver (DR) Module	
Pinout	DT-4V4A (Port 4)	Pinout	DR-4V4A (Port 4)
1	In 1 (-)	1	Out 1 (-)
2	In 1 (+)	2	Out 1 (+)
3	In 2 (-)	3	Out 2 (-)
4	In 2 (+)	4	Out 2 (+)
5	GND	5	GND
6	In 3 (-)	6	Out 3 (-)
7	In 3 (+)	7	Out 3 (+)
8	In 4 (-)	8	Out 4 (-)
9	In 4 (+)	9	Out 4 (+)

The attached figures in section 7 show the module front panel and associated connector location & pinouts.

5.0 Specifications

The tables below identify the specifications for the various signals that these modems transmit/receive.

The DT & DR -4V4A series products transmit and receive the following signals:

Signal Type	Qty	Transmit	Receive
NTSC/PAL video	4	Yes	Yes
Audio (600 OHM, unbalanced)	4	Yes	Yes

The tables below identify the specifications for the various signals that these modems transmit/receive.

Video	DT/DR-4W4A	DT/DR-4V4A
	10-bit Video	8-bit Video
Format	NTSC, PAL, SECAM	NTSC, PAL, SECAM
Voltage/Impedance	1Vp-p, 75 Ohm, 1.5Vp-p	1Vp-p, 75 Ohm, 1.5Vp-p (max)
Differential Gain	<0.6%	<0.6%
Differential Phase	<0.3°	<0.3°
SNR	>67dB (weighted)	>60dB (weighted)
Return Loss	>30dB	>30dB
Field Tilt	<0.5%	<0.5%

Audio	
In/Out Impedance	600 OHM, balanced/unbalanced
Frequency Response	10Hz to 20KHz
SNR	>90dB (weighted) @ 1KHz
In/Out Level	-8 to +8dBm (4Vp-p, max)
THD	<0.01% @ 1KHz
Digitized Resolution	24 bit

Connectors	
Video	BNC connector (one per channel)
Audio	DB9 Female (one for each 4 audio channels)
Optical	Singlemode – ST or FC Multimode - ST

Fiber Type/Size (um)	Optical Output (dBm)	Rx Sensitivity (dBm)	Optical Budget (dB)	Wavelength (nm)	Optical connector	Optical Dynamic Range (dB)
Multimode (FP Laser) 62.5/125	-3	-22	19	850	ST	22
Multimode (FP Laser) 62.5/125	-3	22	19	1300	ST	22
Singlemode 9/125	-3	22	19	1310	ST, FC	22
Singlemode 9/125	+2	-22	24	1310DFB	ST, FC	22
Singlemode 9/125	+3	-22	25	1550DFB	ST, FC	22

6.0 Audio SIM Jumper Settings

Each audio SIM has 4 jumpers for TX and 8 jumpers for RX on it (located directly behind the DB9 connector). There are two jumpers for each channel on RX and one jumper for each channel on TX. These jumpers are used to set the input/output impedance of the audio channels. Each audio input channel can be set to either 600ohm (balanced) or 47kohm (unbalanced) input impedance. Each audio output channel's impedance can be set to either 600 ohm, balanced or low impedance. The default setting is 600 ohm, balanced.

The figures below illustrate these jumpers and how they are configured

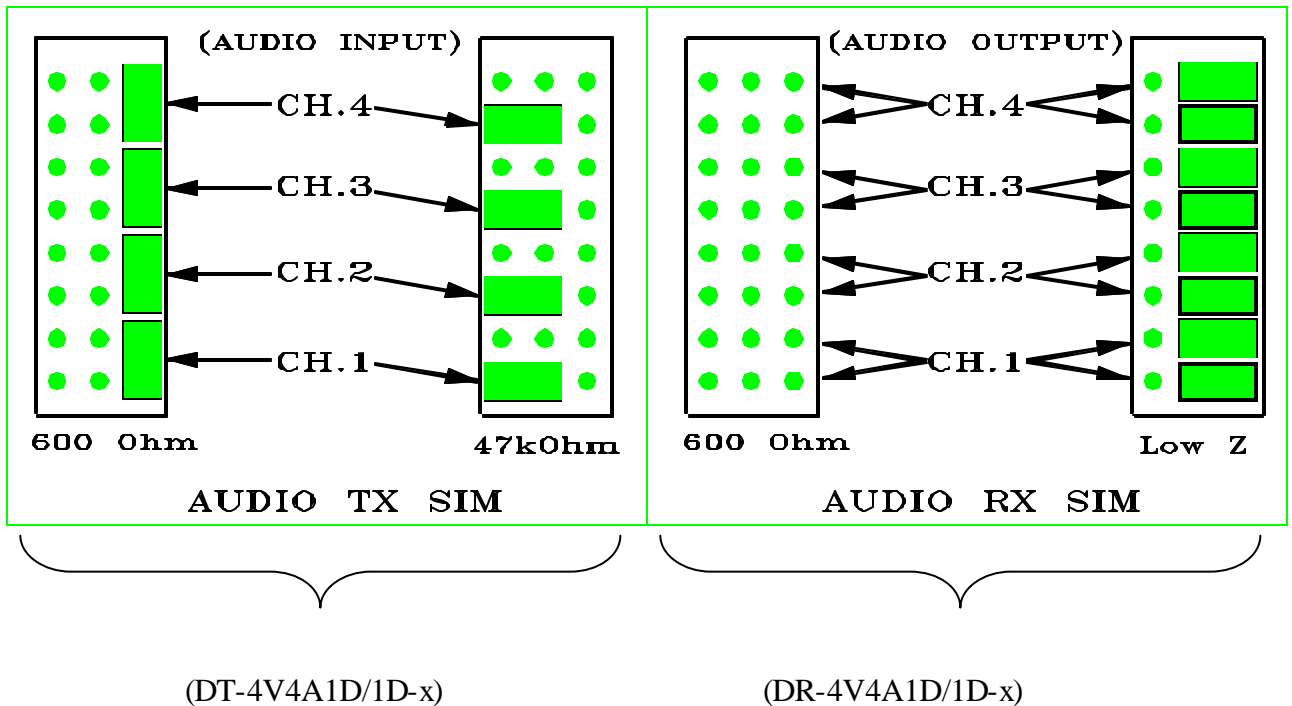

7.0 Front Panel Pinout Assignment Diagram

Figures 7.1 and 7.2 below show the front panel layout, connector location and pinout assignment for both the DT & DR modules.

12/03/2005 V.1

STATUS INDICATORS

- 1. POWER (GREEN)
- 2. NA

STATUS INDICATORS

- 1. TX CARRIER (GREEN)
- / ERROR (RED)

VIDEO INPUT (CH.1)

STATUS INDICATORS

- 1. SYNC PRESENT (GREEN)
- 2. VIDEO PRESENT (GREEN)
- / OVERLOAD (RED)

VIDEO INPUT (CH.3)

STATUS INDICATORS

- 1. SYNC PRESENT (GREEN)
- 2. VIDEO PRESENT (GREEN)
- / OVERLOAD (RED)

AUDIO INPUT (PORT 4) (DB-9 FEMALE)

- 1. (CH.1) INPUT-
- 2. (CH.1) INPUT+
- 3. (CH.2) INPUT-
- 4. (CH.2) INPUT+
- 5. GND
- 6. (CH.3) INPUT-
- 7. (CH.3) INPUT+
- 8. (CH.4) INPUT-
- 9. (CH.4) INPUT+

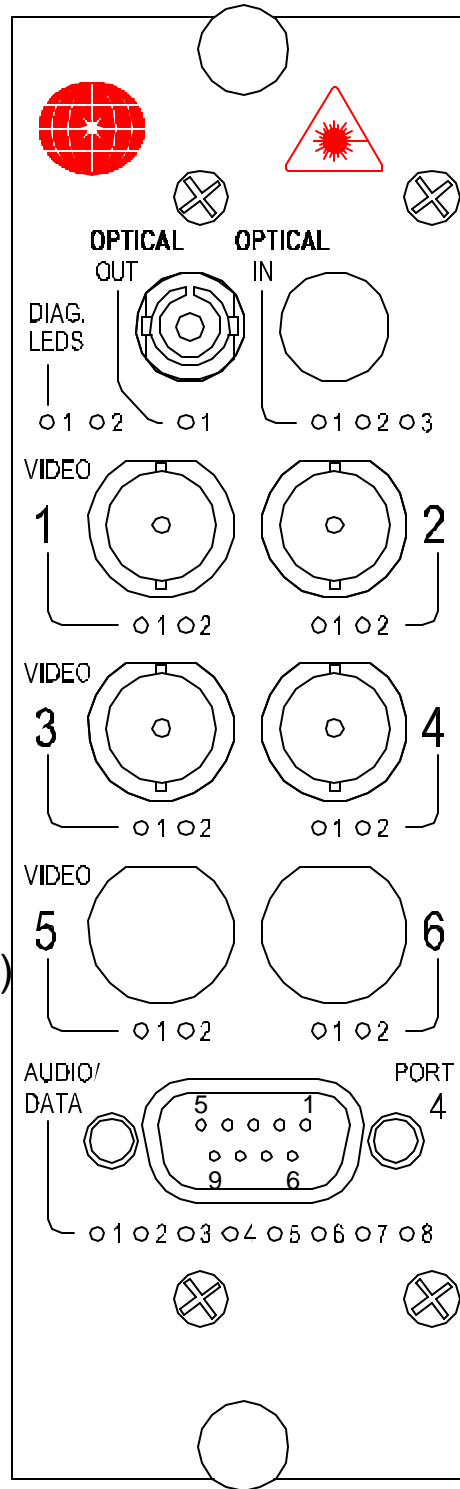

DT-4V4A-x

PINOUT DIAGRAM

VIDEO INPUT (CH.2)

STATUS INDICATORS

- 1. SYNC PRESENT (GREEN)
- 2. VIDEO PRESENT (GREEN)
- / OVERLOAD (RED)

VIDEO INPUT (CH.4)

STATUS INDICATORS

- 1. SYNC PRESENT (GREEN)
- 2. VIDEO PRESENT (GREEN)
- / OVERLOAD (RED)

STATUS INDICATORS (PORT 4)

- 1. (CH.1) AUDIO INPUT PRESENT
- 2. (CH.1) AUDIO INPUT OVERLOAD
- 3. (CH.2) AUDIO INPUT PRESENT
- 4. (CH.2) AUDIO INPUT OVERLOAD
- 5. (CH.3) AUDIO INPUT PRESENT
- 6. (CH.3) AUDIO INPUT OVERLOAD
- 7. (CH.4) AUDIO INPUT PRESENT
- 8. (CH.4) AUDIO INPUT OVERLOAD

Figure 7.1
DT-4V(W)4A-x Front Panel Diagram

12/03/2005 V.1

STATUS INDICATORS

1. POWER (GREEN)
2. NA

VIDEO OUTPUT (CH.1)

STATUS INDICATORS

1. SYNC PRESENT (GREEN)
2. VIDEO PRESENT (GREEN)
/ OVERLOAD (RED)

VIDEO OUTPUT (CH.3)

STATUS INDICATORS

1. SYNC PRESENT (GREEN)
2. VIDEO PRESENT (GREEN)
/ OVERLOAD (RED)

AUDIO OUTPUT (PORT 4)

(DB-9 FEMALE)

1. (CH.1) OUTPUT-
2. (CH.1) OUTPUT+
3. (CH.2) OUTPUT-
4. (CH.2) OUTPUT+
5. GND
6. (CH.3) OUTPUT-
7. (CH.3) OUTPUT+
8. (CH.4) OUTPUT-
9. (CH.4) OUTPUT+

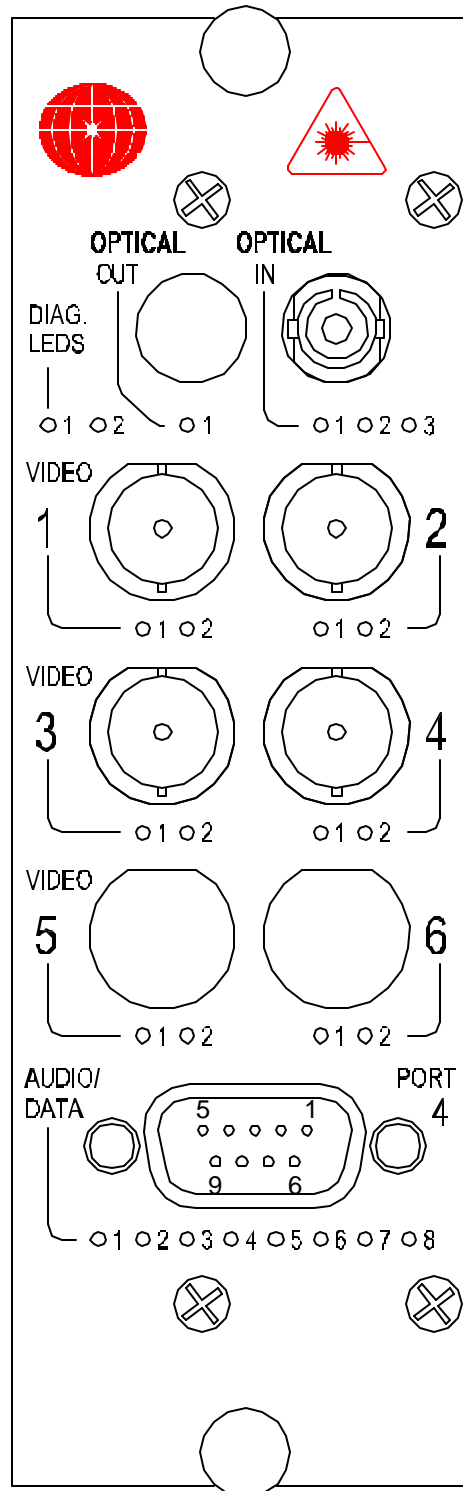

DR-4V4A-x PINOUT DIAGRAM

OPTICAL PORT

STATUS INDICATORS

1. RX OPTICAL SIGNAL (GREEN)
/ ABSENT (RED)
2. NA
3. RX CARRIER (GREEN)/ERROR (RED)

VIDEO OUTPUT (CH.2)

STATUS INDICATORS

1. SYNC PRESENT (GREEN)
2. VIDEO PRESENT (GREEN)
/ OVERLOAD (RED)

VIDEO OUTPUT (CH.4)

STATUS INDICATORS

1. SYNC PRESENT (GREEN)
2. VIDEO PRESENT (GREEN)
/ OVERLOAD (RED)

STATUS INDICATORS (PORT 4)

1. (CH.1) AUDIO OUTPUT PRESENT
2. (CH.1) AUDIO OUTPUT OVERLOAD
3. (CH.2) AUDIO OUTPUT PRESENT
4. (CH.2) AUDIO OUTPUT OVERLOAD
5. (CH.3) AUDIO OUTPUT PRESENT
6. (CH.3) AUDIO OUTPUT OVERLOAD
7. (CH.4) AUDIO OUTPUT PRESENT
8. (CH.4) AUDIO OUTPUT OVERLOAD

Figure 7.2
DR-4V(W)4A-x Front Panel Diagram

8.0 Troubleshooting

Below is a listing of several problems that may arise during the installation & operation of the modules. If you are having difficulty installing or operating the modules please refer to this list below.

Problem: *Module does not fit in chassis slots*

Action: Check module orientation. Meridian “Globe” must be oriented on the top left hand side of the module
Make sure the card guides in the chassis are aligned with the extrusion on the module

Problem: *Card power LED does not light when power to the module/subrack is applied or power indicator turns on and off*

Action: Check power supply to ensure that it is plugged in and turned on. If flashing continues, move module to another chassis or location in the same chassis, if available.

Problem: *No video at output of module*

Action: Check to ensure that the video channel-specific LEDs are on (Green). Also, check to ensure that the optical LEDs are ON (Green). If no video is still present, check to ensure that the monitor is ON and the video cable is connected to the correct video port on the Rx module.

Problem: *Video image is dark*

Action: Check the iris control on the camera to ensure that it is open to the proper amount for the conditions

Problem: *Video image is too bright and appears overexposed*

Action: Check the Video overload indicator on the Rx module. If it is Red, the video signal level is too high and the CCTV iris should be checked to ensure that it is open properly for the conditions.

Problem: *No Audio*

Action: Check the audio input status indicator lights on the transmit module to ensure that they are on (indicating an audio input signal). Also check the audio output status indicator lights on the corresponding receiver module to ensure that the signal is being transmitted and received. If not, please check the audio input/output and fiber connections.

Problem: *Low/High Audio output*

Action: Check to ensure that the input/output impedance properly matches the impedance of the audio input source and output device.

Problem: *Audio distortion on output*

Action: Check the status of the associated channel input/output Overload LEDs. If they are on, reduce the audio input level at the source to bring it below the overload condition. This should resolve problem.

If the problem still persists after reviewing the above items, please contact Meridian technical support (516-285-1000).

Appendix 1 – Applicable Product Part Number Variations

The table below indicates the part numbers and product description that are included in this manual. The pinout diagram in section 4.0 shows the connector pinouts (input/output connections) for the all-inclusive product. The appropriate modules consist of various combinations of 4 uni-directional Audio channels. Please use this table to determine the exact pinout and port location of the particular model of interest.

Product Part Number		# Video Channels & Type		# of Audio Channels	Optical Connect	Fiber Type
Transmitter	Receiver	10-bit	8-bit			
DT-4V4A-1	DR-4V4A-1	--	4	4	ST	Multimode
DT-4V4A1-3	DR-4V4A-3	--	4	4	FC	Singlemode
DT-4V4A-3ST	DR-4V4A-3ST	--	4	4	ST	Singlemode
DT-4W4A-1	DR-4W4A-1	4	--	4	ST	Multimode
DT-4W4A1-3	DR-4W4A-3	4	--	4	FC	Singlemode
DT-4W4A-3ST	DR-4W4A-3ST	4	--	4	ST	Singlemode